

FLANGE TOOL INNOVATION

PRODUCT DATA SHEET

SWi20/25TEEX

INNOVATIVE EXTERNAL
HYDRAULIC FLANGE
SPREADING WEDGE

 II 2G ck IIB T5/II 2D ck T100 °C

SPREADING FORCE:

20 T (200 kN) 1st step
24 T (240 kN) 4th step

SPREADING DISTANCE:

6.0 mm - 103.5 mm (0.24" - 4.1")

WEIGHT: 6.4 kg (14.1 lb)

CAPABILITIES

At 700 bar (10 000 psi):
20 T spread force (1st step)
24 T spread force (4th step)

6.0 mm – 87.5 mm
(0.24" - 3.4") spread over 4 steps
(without stepped blocks)

48.5 mm – 103.5 mm
(1.9" - 4.1") spread over 2 steps
(with stepped blocks)

6.0 mm – 40.0 mm
(0.24" - 1.6") spread
using only 1st step



TOOL DIMENSIONS - CLOSED

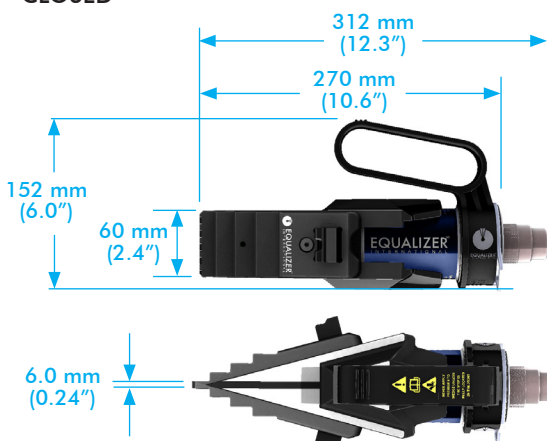

USER FEATURES

- Certified for use in the hazardous areas:
II 2G ck IIB T5/II 2D ck T100 °C
- Practical, portable and lightweight
- Moulded plastic handle for comfort
- Revolving handle to aid horizontal or vertical spreading
- Offset handle is directly over the centre of mass
- Removable handle for improved access
- Revolving lanyard connection point
- Swivel hose coupler with elbow – improves access by allowing hose to revolve
- Spread indicator markings for clear precise visual progress feedback

SAFETY FEATURES

- No finger pinch-points
- Increased step depth on upper steps
- Safety lanyard – 1.0 m (39") length
- Partially recessed coupler reduces coupler vulnerability
- Forged key components for strength and reliability
- Fail-safe design – designated cylinder nose seal failure

MAINTENANCE FEATURES

- Rapid disassembly and assembly
- Quick jaw replacement – remove 1 fastener
- Quick tip replacement – remove 2 fasteners
- Narrow jaw teeth – improved tool wear

info@equalizerinternational.com
www.equalizerinternational.com

SWi20/25TEEX

INNOVATIVE EXTERNAL HYDRAULIC
FLANGE SPREADING WEDGE



FLANGE TOOL INNOVATION

JAW DIMENSIONS (WITHOUT STEPPED BLOCKS ATTACHED)

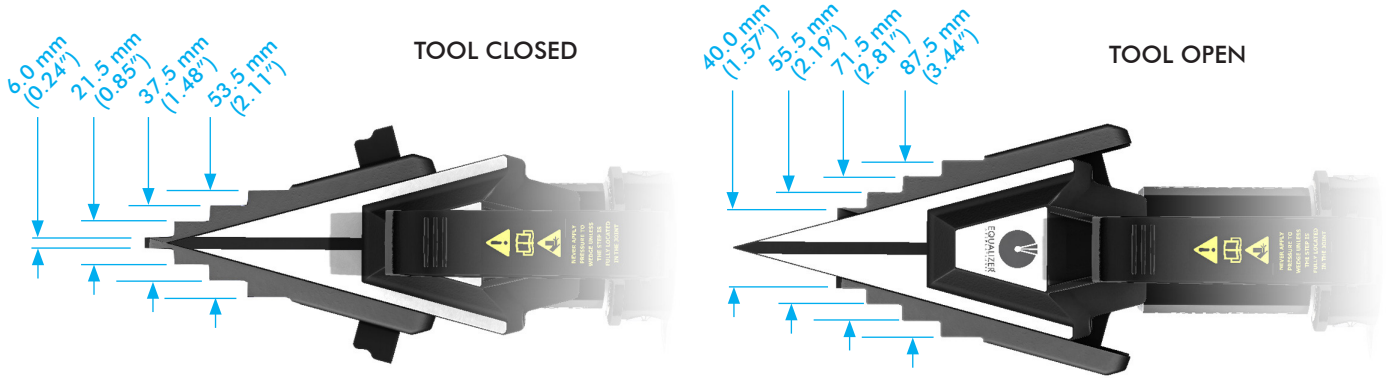

JAW DIMENSIONS (WITH STEPPED BLOCKS ATTACHED)

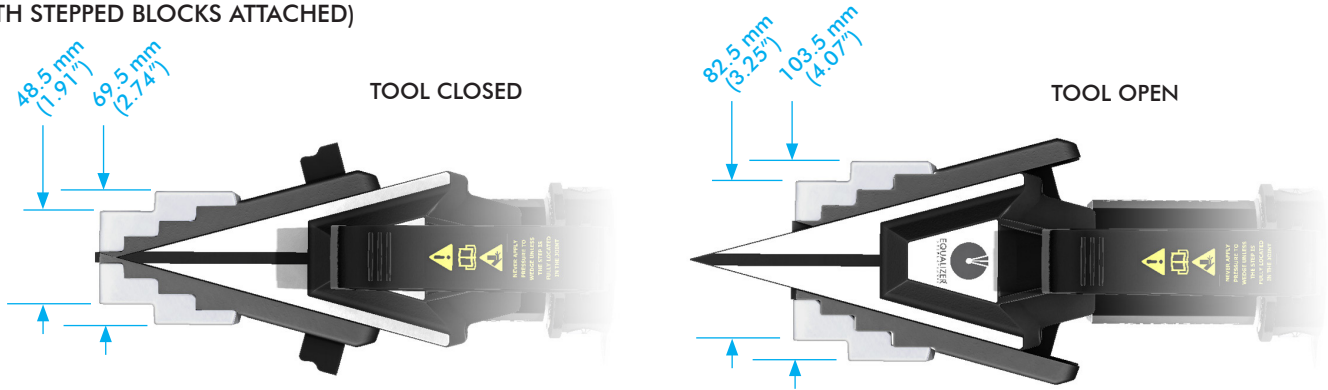

MAXI KIT

- 2 x SWi20/25TEEX Flange Spreader Wedgeheads
- 2 x 700 bar (10 000 psi) Hydraulic Cylinders
- 2 x 700 bar (10 000 psi) ATEX Hydraulic Hoses, 2 m (78.8") with 90 degree elbow
- 1 x 700 bar (10 000 psi) HP550DMINEX Sealed Hand Pump with Gauges
- 2 x Sets of Safety Blocks
- 2 x Pairs of Stepped Blocks
- 2 x Hex Keys
- 2 x Safety Lanyards
- 1 x Instruction Manual
- 1 x Carry Case

Product Code: SWi2025TEMAXEX
Carry Case Dimensions:
930mm x 600mm x 180mm (36.6" x 23.6" x 7.1")
Gross kit Weight: 38.8 kg (85.5 lb)



STANDARD KIT

- 1 x SWi20/25TEEX Flange Spreader Wedgehead
- 1 x 700 bar (10 000 psi) Hydraulic Cylinder
- 1 x 700 bar (10 000 psi) ATEX Hydraulic Hose, 2 m (78.8") with 90 degree elbow
- 1 x 700 bar (10 000 psi) HP350SMINEX Sealed Hand Pump with Gauge
- 1 x Set of Safety Blocks
- 1 x Pair of Stepped Blocks
- 1 x Hex Key
- 1 x Lanyard
- 1 x Instruction Manual
- 1 x Carry Case

Product Code: SWi2025TESTDEX
Carry Case Dimensions:
680mm x 560mm x 180mm (26.8" x 22.0" x 7.1")
Gross kit Weight: 27.5 kg (60.5 lb)



MINI KIT

- 1 x SWi20/25TEEX Flange Spreader Wedgehead
- 1 x 700 bar (10 000 psi) Hydraulic Cylinder
- 1 x Set of Safety Blocks
- 1 x Pair of Stepped Blocks
- 1 x Hex Key
- 1 x Lanyard
- 1 x Instruction Manual
- 1 x Carry Case

Product Code: SWi2025TEMINEX
Carry Case Dimensions:
580mm x 400mm x 180mm (22.8" x 15.7" x 7.1")
Gross kit Weight: 15.0 kg (33.0 lb)